

LED Flat Panel Light

HDSBPA-300×200□-24-55D

\* Only 24V USE

\* Electric Power Consumption 55W

(Note) Please do not remove the tags attached to the product.  
Light-emitting part during lighting, please do not look directly.

(注) 製品に取り付けられているタグは外さないでください。

点灯中の発光部は、直視しないでください。

HR

HAYASHI-REPIC

□	Color
R (red)	
B (blue)	
AW (White)	

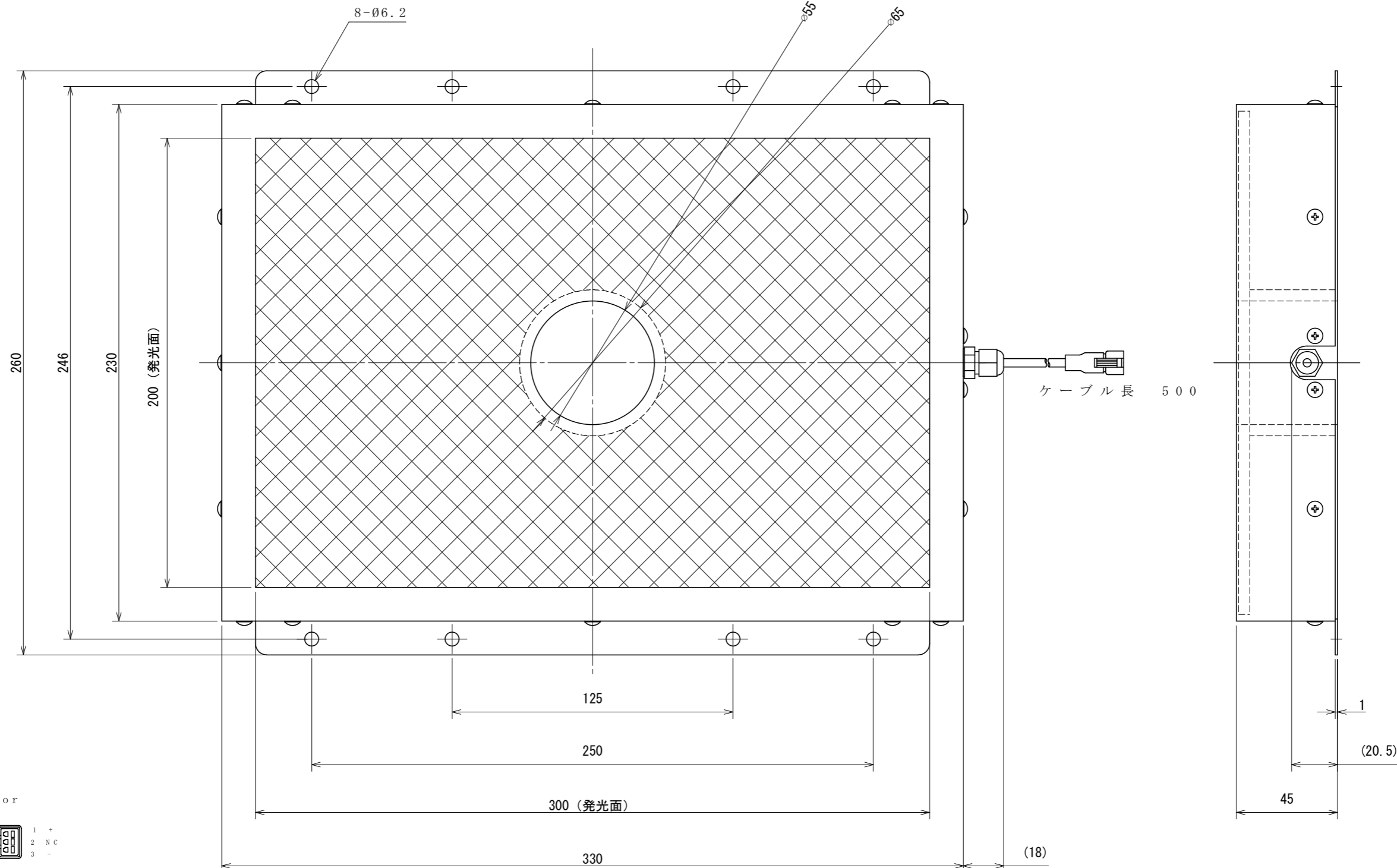

Details of Connector

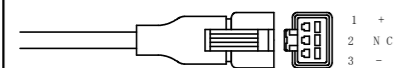

	Light	Power Supply
Connector	SMR-03V-B	SMP-03V-BC
Contact	BYM-001T-P0.6	BHF-001T-0.8SS